



# MIC5234YME Evaluation Board

## Low-Quiescent Current 150mA LDO Regulator

### General Description

The MIC5234 is a low-quiescent current,  $\mu$ Cap low-dropout regulator. A maximum operating input voltage of 30V and quiescent current of 20 $\mu$ A make it ideal for supplying keep-alive power in systems with high-voltage batteries.

Capable of 150mA output, the MIC5234 has a dropout voltage of only 320mV. It can also survive an input transient of -20V to +32V. The MIC5234 needs only a 2.2 $\mu$ F output capacitor for stable operation.

The MIC5234 is available in an 8-pin ePad SOIC package with a junction operating range from -40°C to +125°C.

Data sheets and support documentation are available on the Micrel web site: [www.micrel.com](http://www.micrel.com).

### Requirements

The MIC5234YME Evaluation Board requires a 2.3V to 30V power supply, and a test load. Make sure that the power supply can provide the wattage needed for the chosen test load. The load can be active (electronic load) or passive (resistor). Additionally, monitor the Power Good output (PG) with a multimeter or an oscilloscope.

### Precautions

There is no reverse input protection on this board. While connecting supplies and signals, make sure that correct polarities are observed.

### Getting Started

#### 1. $V_{IN}$ Supplies

Connect the  $V_{IN}$  supply (2.3V to 30V) across the VIN and GND terminals. Monitor  $V_{IN}$  at the VIN and GND terminals with a voltmeter. JP1 is a 2-pin header test point provided for monitoring  $V_{IN}$ .

#### 2. Enable Inputs

The enable input EN is logic high active and needs pull up to input or a voltage source. When EN is pulled low the output is off; when EN is high the output is on.

#### 3. Monitor Outputs

Monitor the output  $V_{OUT}$  with a scope or DVM connected across the VOUT and GND terminals.

#### 4. Output Load

Connect a load across the VOUT and GND terminals. Use an active or passive load.

#### 5. Turn On the Power

Turn on the power supply and verify that  $V_{OUT} = 1.8V$ .

### Ordering Information

Part Number	Description
MIC5234YME EV	Evaluation Board for the MIC5234YME

## Evaluation Board Features

See the *MIC5234 Data Sheet* for detailed explanations of these functions.

### Enable (EN)

EN allows the MIC5234 to turn on/off. A logic low on EN pin keeps MIC5234 in shutdown mode with a typical 0.1µA input current.

### Output Adjust (ADJ)

The MIC5234 can be adjusted from 1.24V to 20V by using two external resistors. The resistors set the output voltage based on Equation 1:

$$V_{\text{OUT}} = V_{\text{REF}} \times \left( 1 + \frac{R1}{R2} \right) \quad \text{Eq. 1}$$

Where  $V_{\text{REF}} = 1.23\text{V}$ .

The evaluation board is provided with  $R2=120\Omega$  and jumper (JP3-JP6) to easily set the output voltage to 5V, 3.3V, 2.5V, and 1.8V.

### Reverse Current Protection

The MIC5234 is designed to limit the reverse current flow from output to input if the MIC5234 output has been tied to the output of another power supply.

### Output Capacitor

The MIC5234 has been designed to minimize the effect of the output capacitor ESR on the closed loop stability. As a result, ceramic or film capacitors can be used at the output. Stability can also be maintained throughout the specified load and line conditions with 2.2µF film or ceramic capacitors.

### Input Capacitor

An input capacitor may be needed when the device is not near the source power supply or when it is supplied by a battery. Small, surface mount, ceramic capacitors can be used for bypassing. Larger values may be needed if the source supply has high ripple.

### Evaluation Board Schematic

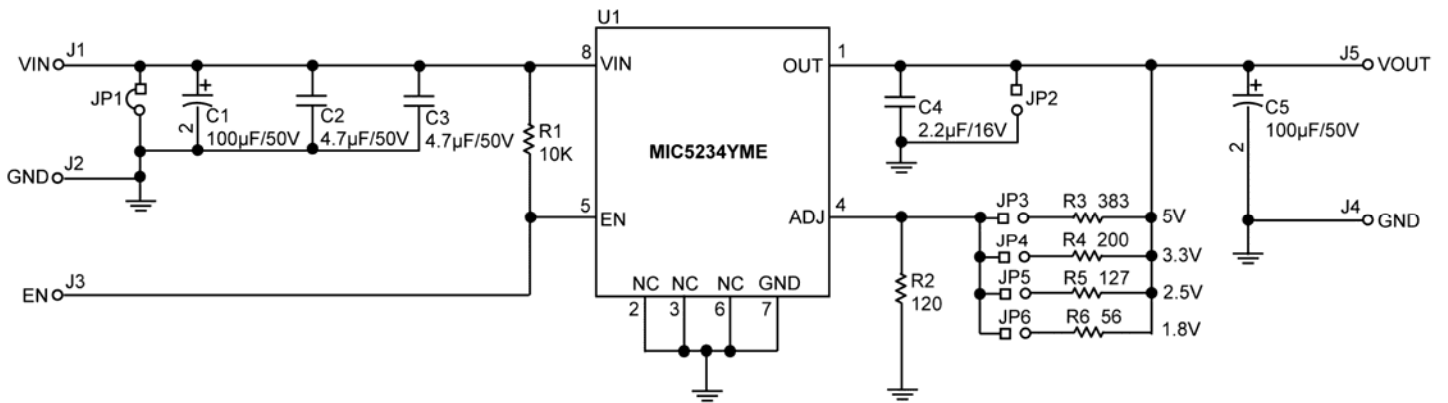

### Bill of Materials

Item	Part Number	Manufacturer	Description	Qty.
C1, C5	EKY-500ELL101MHB5D	United Chemi-con <sup>(1)</sup>	Capacitor, Aluminum, 100µF, 50V, 20%, Radial	2
C2, C3	12065C475KAT2A	AVX <sup>(2)</sup>	Capacitor, 4.7µF, 50V, X5R, size 1206	2
	GRM31CR71H475KA12L	Murata <sup>(3)</sup>		
	C3216X5R1H475K	TDK <sup>(4)</sup>		
C4	0805YD225KAT2A	AVX	Capacitor, 2.2µF, 16V, X7R, size 0805	1
	GRM219R61C225KA88D	Murata		
	C2012X7R1C225K	TDK		
R1	CRCW060310K0FKEA	Vishay <sup>(5)</sup>	Resistor, 10KΩ, 1%, size 0603	1
R2	CRCW06031200FKEA	Vishay	Resistor, 120Ω, 1%, size 0603	1
R3	CRCW06033830FKEA	Vishay	Resistor, 383Ω, 1%, size 0603	1
R4	CRCW06032000FKEA	Vishay	Resistor, 200Ω, 1%, size 0603	1
R5	CRCW06031270FKEA	Vishay <sup>(5)</sup>	Resistor, 127Ω, 1%, size 0603	1
R6	CRCW060356R0FKEA	Vishay	Resistor, 56Ω, 1%, size 0603	1
U1	MIC5234YME	Micrel <sup>(6)</sup>	Low-Quiescent Current µCap LDO Regulator	1

**Notes:**

1. United Chemi-Con: [www.chemi-con.com](http://www.chemi-con.com).
2. AVX: [www.avx.com](http://www.avx.com).
3. Murata: [www.murata.com](http://www.murata.com).
4. TDK: [www.tdk.com](http://www.tdk.com).
5. Vishay: [www.vishay.com](http://www.vishay.com).
6. Micrel, Inc.: [www.micrel.com](http://www.micrel.com).

### Evaluation Board PCB Layout

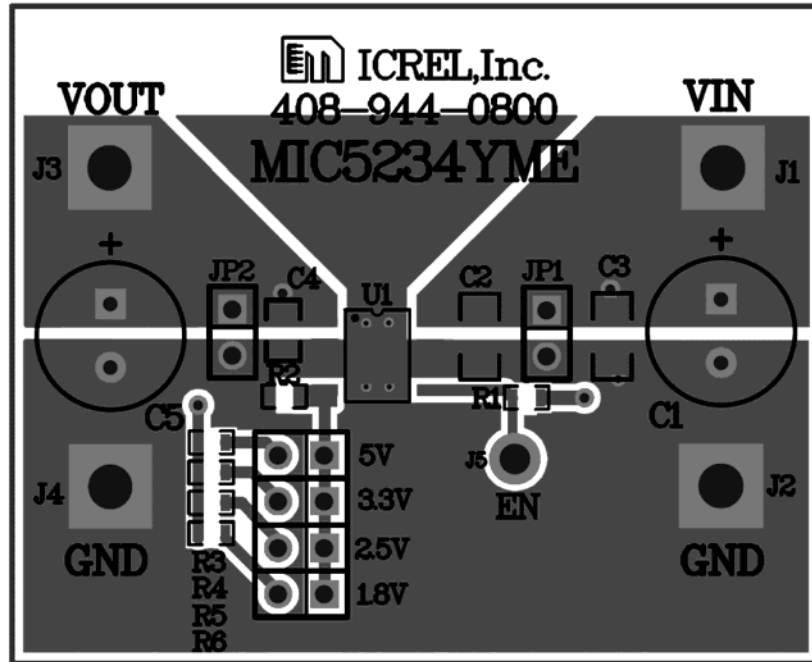

MIC5234 Evaluation Board Top Layer

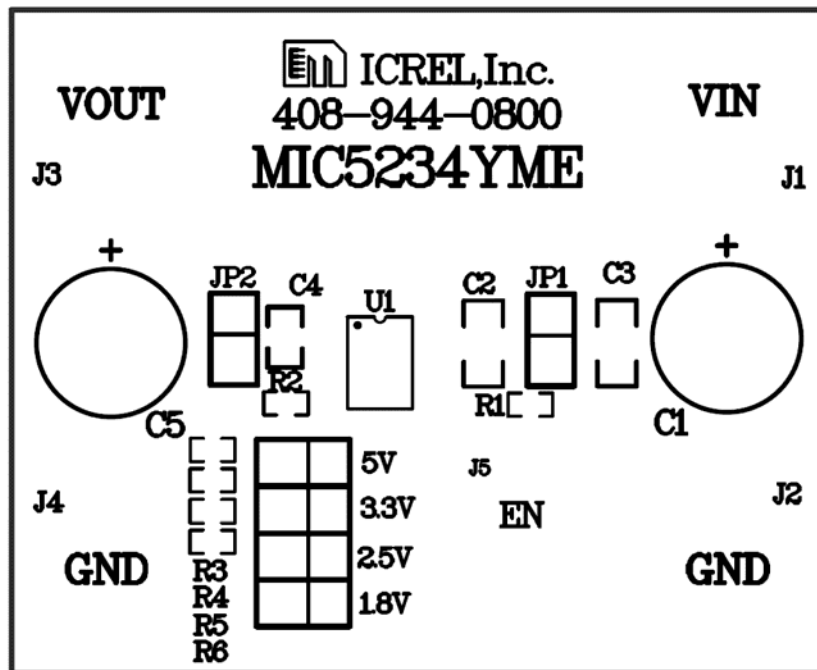

MIC5234 Evaluation Board Top Silk

### Evaluation Board PCB Layout (Continued)

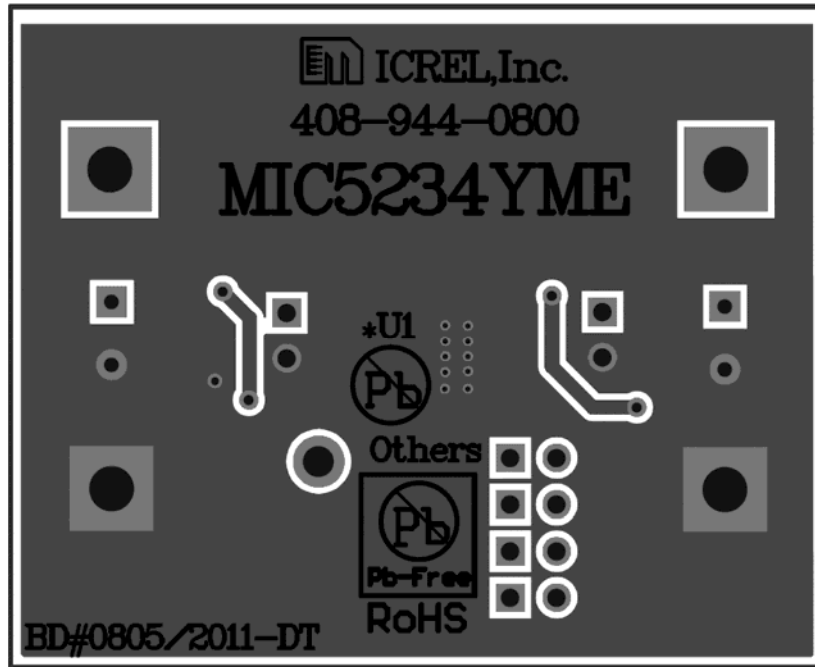

MIC5234 Evaluation Board Bottom Layer

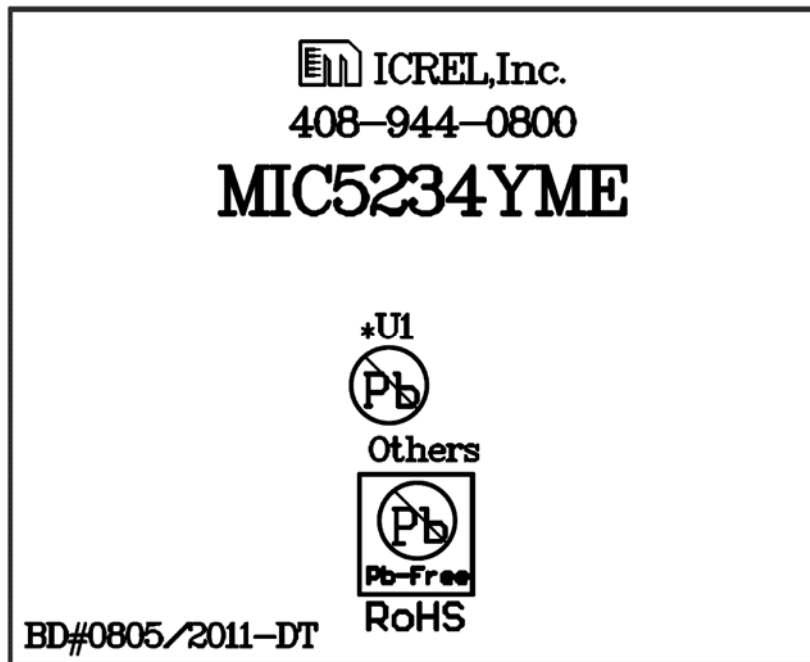

MIC5234 Evaluation Board Bottom Silk

---

**MICREL, INC. 2180 FORTUNE DRIVE SAN JOSE, CA 95131 USA**TEL +1 (408) 944-0800 FAX +1 (408) 474-1000 WEB [www.micrel.com](http://www.micrel.com)

Micrel makes no representations or warranties with respect to the accuracy or completeness of the information furnished in this data sheet. This information is not intended as a warranty and Micrel does not assume responsibility for its use. Micrel reserves the right to change circuitry, specifications and descriptions at any time without notice. No license, whether express, implied, arising by estoppel or otherwise, to any intellectual property rights is granted by this document. Except as provided in Micrel's terms and conditions of sale for such products, Micrel assumes no liability whatsoever, and Micrel disclaims any express or implied warranty relating to the sale and/or use of Micrel products including liability or warranties relating to fitness for a particular purpose, merchantability, or infringement of any patent, copyright or other intellectual property right.

Micrel Products are not designed or authorized for use as components in life support appliances, devices or systems where malfunction of a product can reasonably be expected to result in personal injury. Life support devices or systems are devices or systems that (a) are intended for surgical implant into the body or (b) support or sustain life, and whose failure to perform can be reasonably expected to result in a significant injury to the user. A Purchaser's use or sale of Micrel Products for use in life support appliances, devices or systems is a Purchaser's own risk and Purchaser agrees to fully indemnify Micrel for any damages resulting from such use or sale.

© 2012 Micrel, Incorporated.